

TD Series Temperature Controller Instruction Manual

Thanks a lot for selecting the product!

Before operating this instrument, please carefully read this manual and fully understand its contents. If any problems please contact our sales or distributors whom you buy from. This manual is subject to change without prior notice.

Warning

Please do not turn on the power supply until all of the wiring is completed. Otherwise electrical shock, fire or malfunction may result.

Do not wire when the power is on. Do not turn on the power supply when cleaning this instrument. Do not disassemble, repair or modify the instrument. This may cause electrical shock, fire or malfunction. Use this instrument in the scope of its specifications. Otherwise fire or malfunction may result. The use life of the output relay is quite different according to its capacity and conditions. If use out of its scope, fire or malfunction may result.

Caution

This instrument should be installed in a domestic environment. Otherwise electrical shock, fire or malfunction may result. To avoid using this instrument in environment full of dust or caustic gas. To avoid using this instrument in environment of strong shock or concussion. To avoid using this instrument in environment of overflow water or explosive oil. The power supply wire should not put together with large current wire to avoid electromagnetic radiation, if it must be put together, we suggest to use a individual pipe. In case the instrument is used in environment of strong noise, (such as motor, transformer, solenoid, etc.) a current suppresser or noise filter should be used.

Applications

TA series of temperature controller is available for many TC or RTD input, adopt some advanced technology such multi digital filter circuit, autotune PID, fuzzy PID that make it is very precise, stable, strong anti-interference and simple operation. The instrument is widely applied to

automation systems of mechanism, chemical industrial, chinaware, light industrial, metallurgy and petroleum chemical industrial. It is also applied to the production line of foodstuff, packing, printing, dry machine, metal heat process equipment to control the temperature.

Panel

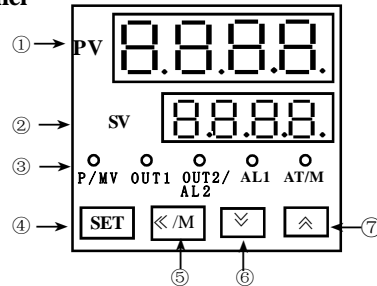

- ①. PV / parameter symbols
- ②. SV / parameters preset value
- ③. Indication lamps

OUT1: Heating/Main control output lamp

On: Output Off: No output

OUT2/AL2: Colling/Alarm 2 output lamp

On: Output Off: No output

AT/M: On: manual operation Off: auto operation

Flash: under autotuning estate

P/MV: SV/MV display setting

On: MV manual output Off: SV setting

AL1: Alarm 1 lamp On: Alarm Off: No Alarm

AL2: Alarm 2 lamp On: Alarm Off: No Alarm

④. Set key Parameter Setting/Changing

⑤. Shift/Autotune key Press this key to shift digit of parameter value setting. Or hold this key for more than 3 seconds can enter/quit autotune estate. When enter autotune estate, AT lamp on. When quit autotune estate, AT lamp off.

⑥. Up key ⑦. Down key

Models

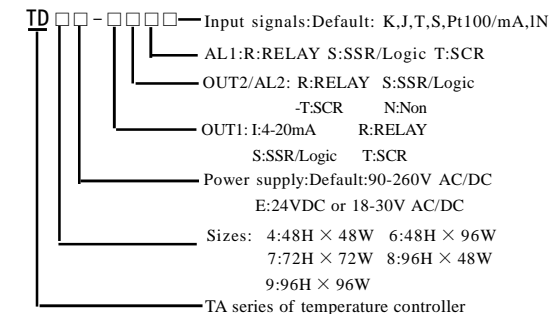

Specifications

Power supply	90~260V AC/DC 50/60Hz	
Consumption	≤ 5VA	
Display range	-199~1800°C	
Accuracy	0.3%F. S ± 2digit	
Sampling cycle	≤ 300ms	
Main output	RELAY: normal open AC 250V/3A DC 30V/3A COS φ=1 SSR/LOGIC : 24V DC ± 2V/ 20mA	
Alarm	RELAY: normal open AC 250V/3A DC 30V/3A COS φ=1 SSR/LOGIC: 24V DC 12V/ 30mA	
Input	T/C	K 0~999°C/0~1200°C
		J 0~999°C /0~1200°C
		T -150~400°C (Special order)
	Rt	S 0~1600°C
		E 0~1000°C
	mV	mV 0~75mV
mA 4~20mA /0~10V		
Withstand voltage strength	1500V Rms (Between power terminal and the housing)	
Insulation resistance	Min 50M Ω (500V DC) (Between power terminal and the housing)	
Environment temperature	0~50°C	
Save temperature	-10~60°C	
Environment humidity	35~85%RH	
Weight	≤ 350g	

Mounting and Sizes

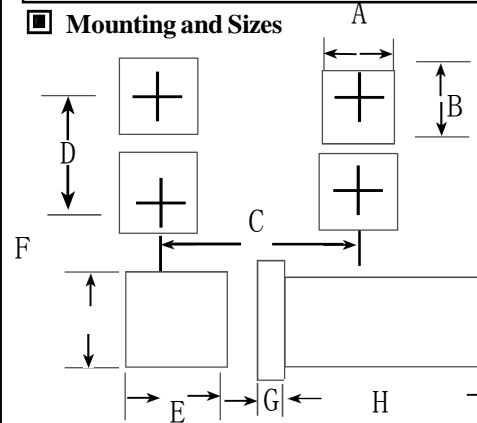

Model	A	B	C	D	E	F	G	H
TD4	44.5+0.5	45+0.5	65	65	48	48	8	80
TD6	43.5+0.5	91+0.5	65	115	48	96	12	80
TD7	91+0.5	91+0.5	115	115	96	96	12	100
TD8	91+0.5	43.5+0.5	65	115	96	48	12	80
TD9	67.5+0.5	67.5+0.5	95	95	72	72	12	100

Parameter Setting & Autotuning

☆ Parameters setting:

A: In display estate, press SET, P/MV lamp on means SV setting, while off means MV manual output setting, but only on manual operation & input connect do MV settable. B: Press the <</M key to select the digit you want to modify; C: Press \wedge and ∇ key to modify the numerals; D: Press SET key to confirm.

☆ In autotuning estate, output value modification is impossible.

☆ Autotuning operation.

In display estate, press SET and <</M key at the same time until AT/M lamp flashes. Then the instrument is under autotuning estate. Press again to quite.

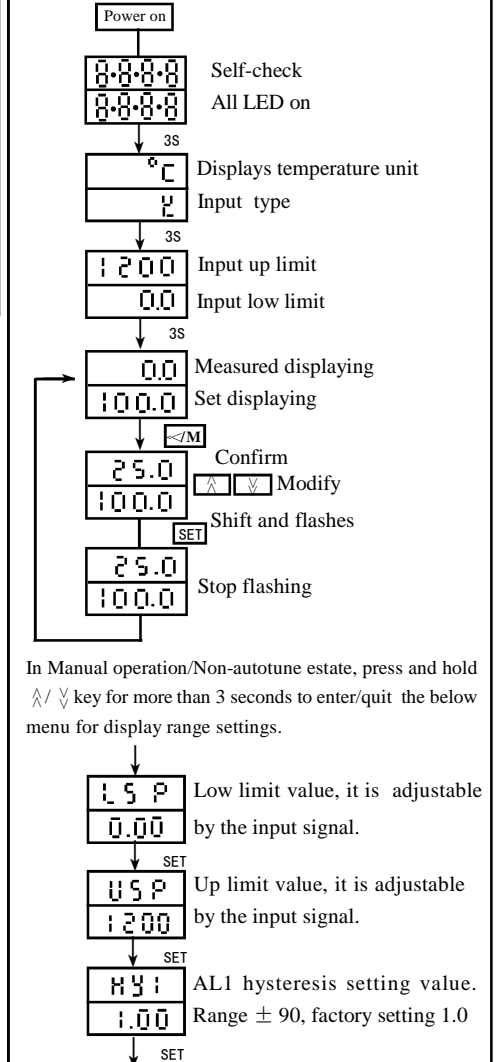

HY2 AL2 hysteresis setting value.
1.00 Range ± 90 , factory setting 1.0
 ↓ SET
dP Decimal point setting:
0 0: No decimal 1: One decimal
 ↓ SET
5cK Password setting.
015 Factory setting 015

↓ HOLD SET >3S
AL1 AL1 set range: -1999-9999
9000
 ↓ SET
AL1 AL1 mode: 0: Deviation HI alarm 1: Deviation LO alarm 2: Absolute value HI alarm 3: Absolute value LO alarm 4: Section outside alarm 5: Section inside alarm 6: TC broken alarm, The factory setting is 2
2
 ↓ SET
AL2 AL2 set range: -1999-9999.
900
 ↓ SET
AL2 AL2 mode: The same as AL1.
3
 ↓ SET
PVF Range: ± 100 . Display value PV = Measured value - PVF
0.00
 ↓ SET
InP Input signal selection TC: K, J, E, S RTD: Pt100, Cu50 The factory setting is K
P
 ↓ SET
3.00 Proportional band (%) range 0.1-3600. If P=OFF, it means ON/OFF control
 ↓ SET
1 Integral time range 0.1-3600. I=OFF means cancel integral time.
2400
 ↓ SET
d Derivative time range 0.1-3600. D=OFF means cancel derivative time.
OFF
 ↓ SET
HEAT Control directions: HEAT: heating COOL: cooling
HEAT
 ↓ SET
HY5 Control hysteresis, range: ± 100 . It is not available when P \neq OFF
1.00
 ↓ SET
REL The output control mode, RELAY=020, SSR/SCR=001, 4-20mA=000.
020

SET
4.00 High analogue output (when analogue is active)
0.00
 ↓ SET
4.00 High analogue output (when analogue is active)
1000
 ↓ SET
b5L Only for 4-20mA **b5L** =PID,control; **b5L** =tPV 4-20mA, transmit;
tPV
 ↓ SET
C-F Temperature unit. C means C degree, F means F degree.
C
 ↓ SET
LcK Parameter lock code setting. LcK=000 means unlocked. LcK=010 means locked.
000

Note:
 Manual/Auto Conversion: In display estate, press <</M to shift. AT/M lamp on means manual operation, while off means autotuning.

For the very first time, please press SET and <</M key until AT/M lamp flash to enter autotuning estate. In the future, if the load/control temp. point changes in small scale (eg. Running the same equipment, and the preset value changes within $\pm 30^{\circ}\text{C}$), the user no need to let it autotuning again. Because the instrument has recorded the previous PID parameters. When the instrument is used for huge capacity heating equipments, the user should set autotuning value lower 5%-10% than the normal control value, in order to decrease the exceed-tuning caused by control.

Normally, the control cycle of the heating equipment should be 20-30 seconds. For huge capacity heating equipments, the value should be 30-120 seconds, in order to longer the use life of the relay. For non-contact output, such as SSR control output, the value should be 1-3.

Terminal configurations
 (If any changed, please refer to the product showing.)

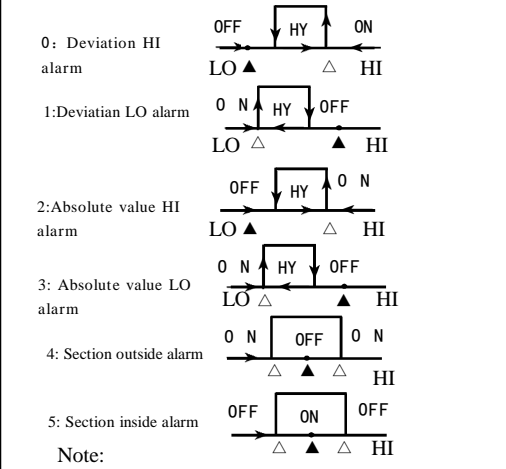
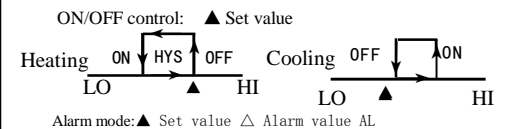
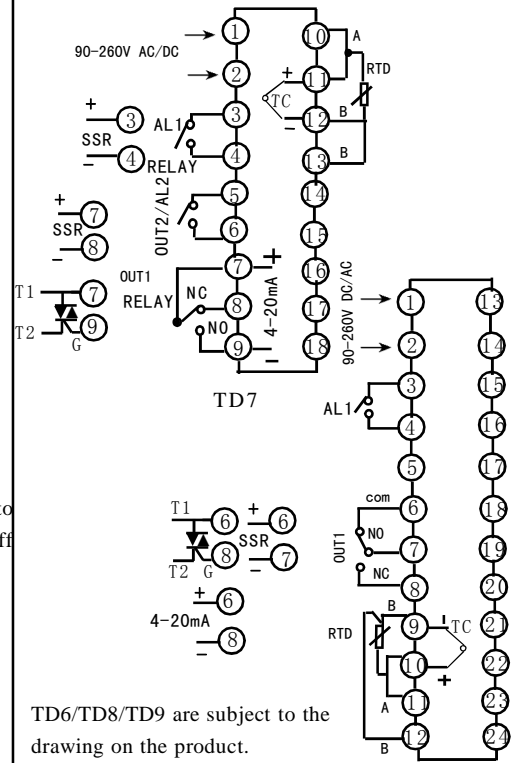
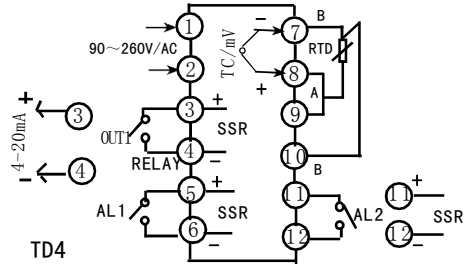

Note:
 All the factory setting value of deviation alarm is 1.0.

Application examples

1. Relay output control (for TA9)

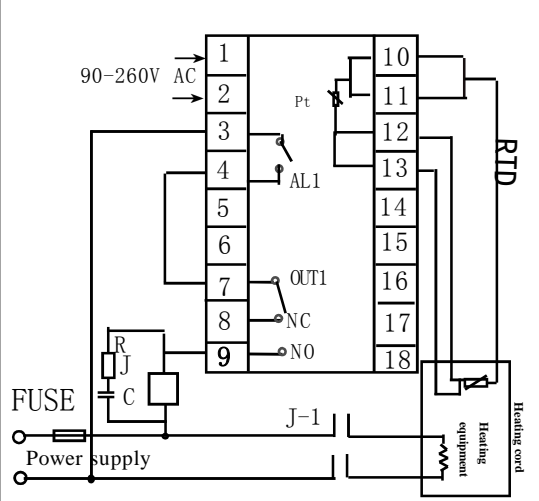

Malfunction estimate

- ① No Display : Check all the connection and wiring if it is all correct. Specially pay attention to the power supply terminals and signal input terminals.
- ② Incorrect Display: Check if the input signal is conformity with the selected symbol. For TC input, please use the relative compensation cable. For RTD input, please use low impedance cable. The 3 wires should at the same length. If all above mentioned is collect, please use parameter PVF to modify.
- ③ Incorrect Control : If the instrument has been used for a long time, the user find the temperature is hard to rise up to the set value, meanwhile the outsidestystem running well, there must be something wrong with the parameters of the instrument. The user need to re-autotuning the instrument. If the instrument lost control, please check if the connection of the control is correct. If external load is shorted, broken, wrong connection or components is damaged, it will cause lost control as well. When it is necessary, please push out the PCB to check the if the output terminals is damaged and not available.
- ④ Display malfunction : "UUUU": The input signal exceed the measured HI range .